

FRONT MOUNT SHELF

Depth 25 and 35cm.

Scope of Application

Modern design, in 19" Standard, provide variety of length which suitable for each depth of cabinet and giving high loading capacity.



CK-12250

CK-12350

LINK AMERICAN STANDARD

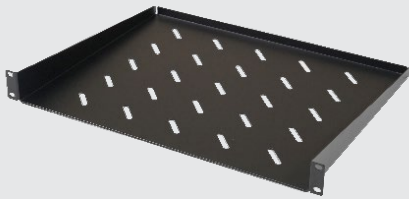

Drawing

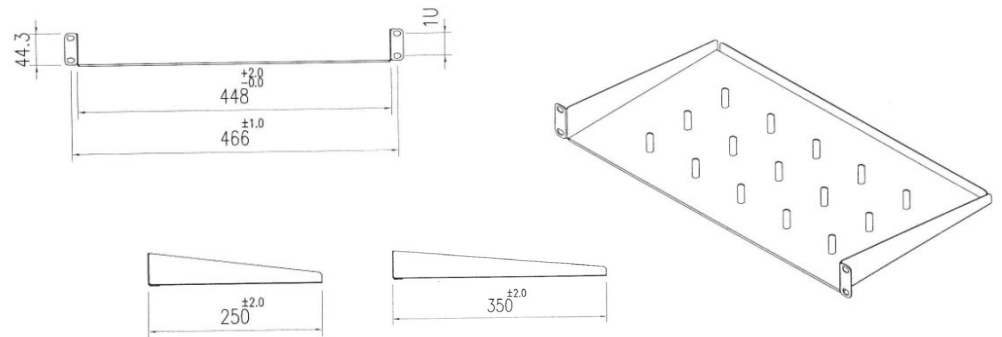

*For reference only

Technical Standard

- ANSI/EIA-310D
- IEC 60297-1
- IEC 60297-2
- BS 5954 Part : 2
- DIN 41494
- 19" Standard
- ISO 9001 :2015





Features

- Designed with 19"LINK RACK
- Perforated surrounding for ventilation
- Suitable for all 19" Rack system.

Material

- 1.5 mm Electro-galvanized steel sheet
- Electrostatic powder coating, Black (RAL9004)

Order Information

Part number	Description	Depth (cm.)
CK-12250	Front Mount Shelf Deep 25cm.	25cm.
CK-12350	Front Mount Shelf Deep 35cm.	35cm.

Specifications subject to change without notice.

© 2023 LINK CORP. ALL RIGHTS RESERVED

www.linkcable.com

CK-12X50-V1.1-121223